

PIZARRAS MÓVILES

MOBILE FLIPCHARTS • MOBILE FLIPCHARTS • TABLEAUX MOBILES

[ESP] Pizarra móvil metálica y magnética, apta para escritura con rotuladores de borrado en seco. Admite bloc de papel universal. No regulable en altura. Incluye 1 brazo telescópico. Fácil montaje.

[ENG] Mobile magnetic metal flipchart for writing with dry-wipe markers. Takes universal paper block. Not height-adjustable. Includes 1 telescopic arm. Easy to assemble.

[DE] Funktionell und mit der Konzentration auf das Wesentliche – das mobile Flipchart mit fester Aufstellhöhe. Stabiler Kunststofffuß. Magnethaftende Tafeloberfläche, für trocken abwischbare Beschriftung geeignet. Schnellwechselblockhalter für marktübliche Flipchart-Papierblöcke. 1 Inklusive Teleskoparm. Feststellbare Laufrollen.

[FR] Tableau mobile métallique, magnétique pour écriture au marqueur effaçable à sec. Peut recevoir bloc de papier universel. Non réglable en hauteur. N'admet pas de bras télescopiques. Inclut 1 bras télescopique. Facile à monter.



Superficie para rotuladores de borrado en seco.
No limpiar con alcohol o productos abrasivos.

Dry wipe surface. Never clean it with alcohol or abrasive products.

Bitte niemals mit reinem Alkohol reinigen und keine Tücher mit abrasiven Eigenschaften verwenden.

Surface effaçable à sec. Ne nettoyer jamais la surface avec de l'alcool ou un produit abrasif.



Incluye un rotulador
Marker included

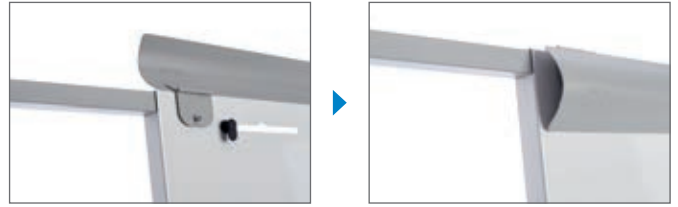

Sistema bloc de papel universal / Universal paper block system



Ruedas a presión
Click system castors

Medidas / Sizes (cm)

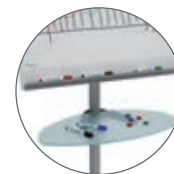
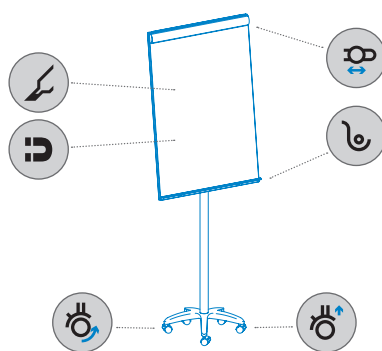
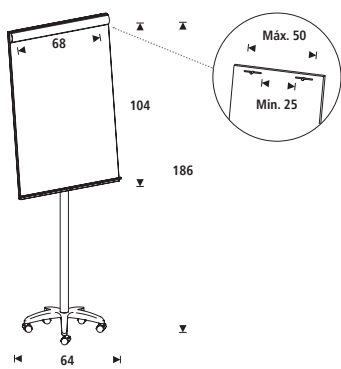

RD-619
Bandeja porta útiles de cristal
Optional glass tray

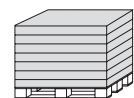

RD-616 - palet / pallet 8 u. - 80x120x120 cm

Ref.	cm (embalaje / packaging)	kg / m ³ (embalaje / packaging)	Color
○ RD-616	115x78,5x12	13,7 kg / 0,108 m ³	blanco / white ○
● RD-616-630*	115x78,5x12	13,7 kg / 0,108 m ³	RAL 630 ●
RD-619 opcional / optional	70x35x8	3 kg / 0.019 m ³	